

VM SERIES
KE7716A

AUTOMATIC COMBINATION WEIGHERS

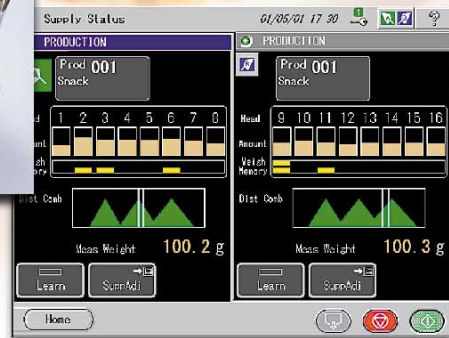

• *High-speed twin*
240 packs/min.



For large-scale production lines of all dried foods, with its 8+8 head high-speed twin weighing function

Features

1. High-speed, high-accuracy twin weighing function

- High-speed weighing of 240 (120 + 120) packs with 16 heads per minute
- Combination accuracy improved thanks to VM method of combining the weighing hopper and the memory hopper

2. A futuristic design for a smooth product flow

- Products can be carried smoothly in the pipeline from the trough through the hopper to the chute.

3. Simple curved surface simplifies cleaning.

- The simple open frame and seamless round hopper make cleaning easier.

4. Supports food safety and environmental friendliness.

- The exterior is built of stainless steel (no painted finish or aluminum).
- Pipeline structure helps prevent the product flow from being contaminated by foreign objects.

5. Easy operation and reliable data management

- Large color TFT LCD screen with Window OS
Easy-to-operate touch panel screen improves operability.
- Operation status as well as alarm records and points to be diagnosed are displayed.

* Windows is a registered trademark in the United States and other countries of United States Microsoft Corporation.

Specifications

Model	KE7716A
Weighing range ^{note}	5 ~ 2000 g
Max. weight capacity ^{note}	3000 ml (Single discharge)
Volume for weighing	2000 ml
Max. speed ^{note}	240 (120 + 120) packs/min.
Accuracy (\bar{X}) ^{note}	0.3 ~ 1.0 g (~ 1000 g), 0.6 ~ 2.0 g (~ 2000 g)
Minimum graduation	0.1 / 0.2 / 0.5 g
Display	10.4-inch color TFT LCD
Operation method	Touch panel
Preset memory	50 product types
Number of weighcells	16
Combination method/ Discharge method	VM (Vertical Memory)/Twin discharge
Power requirements	200 ~ 240 Vac +10% -15%, Single phase 50/60 Hz, 1 kVA
Operation temperature	0 ~ 40°C
Weight	900 kg

Note) Depends on product shape, product density, target weight, etc.

External Dimensions

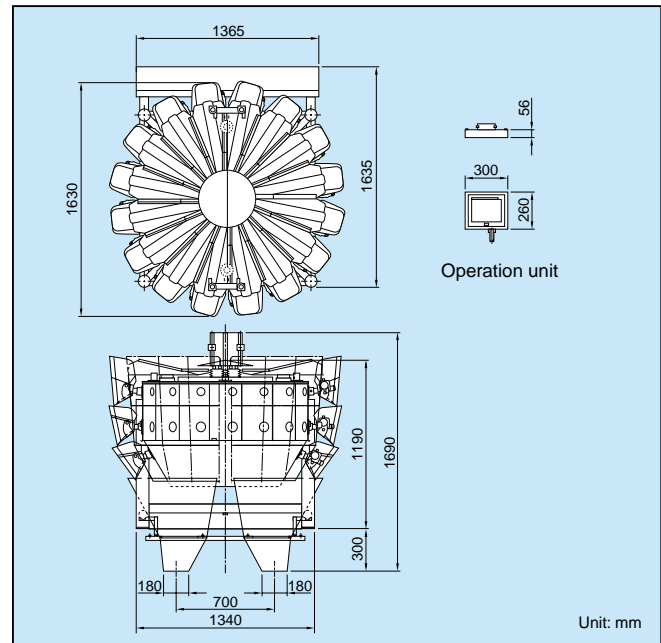

Anritsu

ANRITSU INDUSTRIAL SOLUTIONS CO., LTD.

INTERNATIONAL SALES DEPARTMENT
1800, Onna, Atsugi-shi, Kanagawa-Prf., 243-0032, JAPAN
PHONE +81 46 296 6699
FAX +81 46 225 8387
E-Mail: KPOST@anritsu.co.jp
<http://www.anritsu.co.jp/E/Industry/>

CAT. NO. K3094-A-3



ISO14001 CERTIFICATE No.JQA-EM0210
ISO 9001 CERTIFICATE No.JQA-0566
©ANRITSU INDUSTRIAL SOLUTIONS CO., LTD. 2004

- In addition to daily inspection, an annual maintenance check should be carried out.

Specifications are subject to change without notice. No part of the whole of this catalog may be reproduced without our permission.

r100 Printed on 100%
Recycled Paper

PRINTED WITH
SOYINK™ Printed with environment-friendly
vegetable soybean oil ink.

2004-4 30 (ddc) Printed in Japan